

PROJECT NO. 0080-0132

BRIDGE NO. 01164

South Street over I-84
Middlebury, Connecticut

Virtual Public Information Meeting
March 5, 2024



A recording of the formal presentation will be posted to YouTube after the live event.
Closed captioning, including non-English translation options, will be available at that time.

La grabación de esta presentación estará disponible después del evento en YouTube,
Incluyendo subtítulos y acceso a traducciones en otros idiomas.

Rehabilitation of Bridge No. 01164 // State Project No. 0080-0312





Connecticut Department of Transportation Title VI Notice to the Public

- ◊ The Connecticut Department of Transportation (CTDOT) operates its programs and services without regard to race, color, and national origin in accordance with Title VI of the Civil Rights Act. Any person who believes she or he has been aggrieved by any unlawful discriminatory practice under Title VI may file a complaint with the CTDOT.
- ◊ For more information on the CTDOT's civil rights program, and the procedures to file a complaint, contact the CTDOT Title VI Coordinator at (860) 594-2169, TRS 711; Debra.Goss@ct.gov; or visit our administrative office at 2800 Berlin Turnpike, Newington, CT 06131. For more information, visit www.ct.gov/dot
- ◊ A complainant may file a complaint directly with the Federal Transit Administration by filing a complaint with the FTA Office of Civil Rights, Attention: Title VI Program Coordinator, East Building, 5th Floor-TCR, 1200 New Jersey Ave., SE, Washington, DC 20590
- ◊ A complainant may file a complaint directly with the Federal Highway Administration by filing a complaint with the FHWA Office of Civil Rights, Attention: Title VI Program Coordinator, 8th Floor E81-105, 1200 New Jersey Ave., SE, Washington, DC 20590

如需更多信息或免费语言协助，请致电 (860) 594-2109

Para información adicional, o asistencia lingüística gratuita, por favor llame al (860) 594-2109

Per informazioni aggiuntive o assistenza linguistica gratuita, chiamare il numero (860) 594-2109

Para obter mais informações, ou para auxílio gratuito em outro idioma, ligue para (860) 594-2109

Aby uzyskać dodatkowe informacje lub bezpłatną pomoc tłumacza, proszę dzwonić pod numer (860) 594-2109

Для получения подробной информации или бесплатных услуг перевода звоните по телефону (860) 594-2109

Pou jwenn plis enfòmasyon, oswa asistans ak lang gratis, ranpri rele (860) 594-2109

لمزيد من المعلومات أو للحصول على مساعدة لغوية مجانية، يرجى الاتصال بالرقم (860) 594-2109

Si vous souhaitez en savoir plus ou bénéficier d'une assistance linguistique gratuite, merci de composer le numéro suivant (860) 594-2109

अधिक जानकारी या निःशुल्क भाषा संबंधी सहायता के लिए कृपया (860) 594-2109 पर कॉल करें।

추가 정보가 필요하거나 무료 언어 지원이 필요하시면 (860) 594-2109로 전화하십시오.

Để có thêm thông tin hoặc hỗ trợ ngôn ngữ miễn phí, vui lòng gọi (860) 594-2109

Rehabilitation of Bridge No. 01164 // State Project No. 0080-0312





Departamento de Transporte de Connecticut

Título VI Aviso al Público

- ◊ El Departamento de Transporte de Connecticut (CTDOT) se compromete a asegurar que ninguna persona sea excluida de participar en, o le sean negados los beneficios de, sus servicios de transporte basándose en la raza, color o país de origen de la persona protegida por el Título VI de la Ley de los Derechos Civiles. Si a usted le parece que ha sido objeto de discriminación en lo que corresponde al Título VI, puede presentar una queja al CTDOT.
- ◊ Para más información sobre el programa de derechos civiles del CTDOT y el proceso de presentar una queja, comuníquese con el Coordinadora del Título VI del CTDOT al teléfono (860) 594-2169, TRS 711; Debra.Goss@ct.gov. También puede visitar nuestra oficina administrativa en 2800 Berlin Turnpike, Newington, CT 06131. Para más información, visite www.ct.gov/dot.
- ◊ Un denunciante puede presentar una queja directamente ante la Federal Transit Administration si lo hace ante la FTA Office of Civil Rights, Attention: Title VI Program Coordinator, East Building, 5th Floor-TCR, 1200 New Jersey Ave., SE, Washington, DC 20590.
- ◊ Un denunciante podrá presentar una queja directamente ante la Federal Highway Administration si lo hace ante la FHWA Office of Civil Rights, Attention: Title VI Program Coordinator, 8th Floor E81-105, 1200 New Jersey Ave., SE, Washington, DC 20590.
- ◊ Para recibir más información o ayuda gratuita en otros idiomas, llame al (860) 594-2109.

Rehabilitation of Bridge No. 01164 // State Project No. 0080-0312



Title VI – Your Civil Rights

No Person shall, on the basis of race, color or national origin, be excluded from participation or subject to discrimination in the development of this project.

- Voluntary Post-Meeting Survey:

- <https://portal.ct.gov/ctdotsurvey>



- Civil Rights information:

- <https://portal.ct.gov/DOT/Business/Office-of-Equity/Title-VI-Page>

A recording of this presentation will be posted to YouTube after the event.

Closed captioning—including non-English translation options—are available on Zoom and YouTube.



How to view captions & subtitles in Zoom

1. Click Show Captions (CC).
2. Click the Speaking Language.
3. Select the language you would like from the list shown.

Closed captioning—including non-English translation options—are available on YouTube after the event.



How to use Zoom Q&A

- (1) Select the Q&A tool at the bottom of the Zoom webinar window.
- (2) The Q&A window will open as seen on the right.
- (3) Please type question in the textbox and click enter.
- If you are an audio only participant, dial *9 to raise and lower your hand.

(1)



(2)

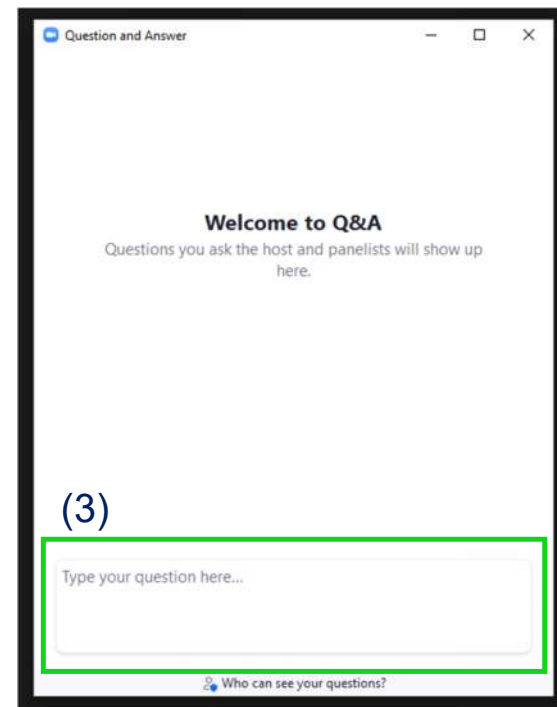

(3)



Question & Answer Session



by email: DOTProject0080-0132@ct.gov



by phone: **(860) 594-2020 (voicemail)**



by chat: **Zoom Q&A**



project webpage:

<https://portal.ct.gov/DOTMiddlebury80-132>

Moderator will answer questions in Zoom Q&A

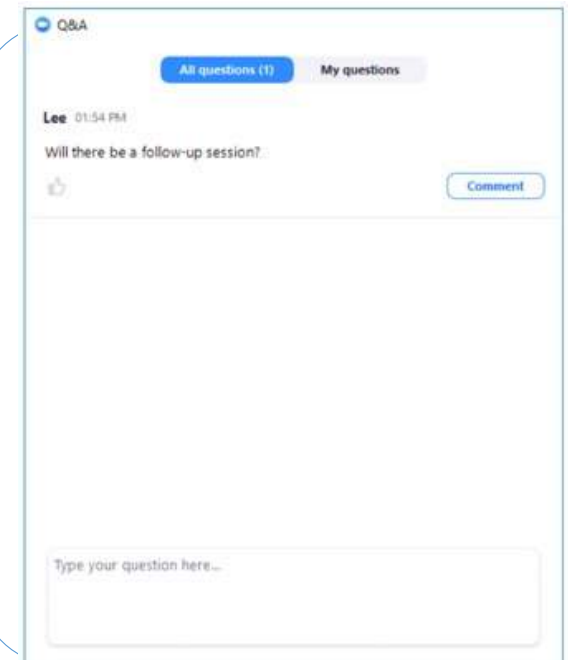

Note: Comment period is open through **March 19, 2024**

*Zoom Q&A is only available during live Q&A session

Rehabilitation of Bridge No. 01164 // State Project No. 0080-0312



PROJECT TEAM

CT Department of Transportation

Derick M. Lessard, P.E. – Principal Engineer – derick.lessard@ct.gov

Francisco T. Fadul, P.E. – Supervising Engineer – francisco.fadul@ct.gov

Corey Burroughs – Project Engineer – corey.burroughs@ct.gov

CHA Consulting Inc., Consultant Liaison Engineer (CLE)

Don Wurst, P.E. – Project Manager – dwurst@chasolutions.com

Jen Pixley, P.E. – Project Engineer – jpixley@chasolutions.com

H&H, LLC, Consulting Designer

Steve Hom, P.E. – Project Manager – shom@hardestyhanover.com

Brian Kinsley, P.E. – Project Engineer – bkinsley@hardestyhanover.com

VN, Inc. Traffic Engineer

Sam Martha – Project Engineer – smartha@vnengineers.com

Rehabilitation of Bridge No. 01164 // State Project No. 0080-0312



PROJECT PURPOSE AND NEED

Purpose – Upgrade to a “State of Good Repair”

- Condition of Bridge Elements
 - Pin & Hanger
 - Deck
 - Superstructure



Need:

- Extend Service life
- Provide a structurally sound deck
- Provide MASH compliant railings



PROJECT LOCATION



Rehabilitation of Bridge No. 01164 // State Project No. 0080-0312



BRIDGE ELEVATION

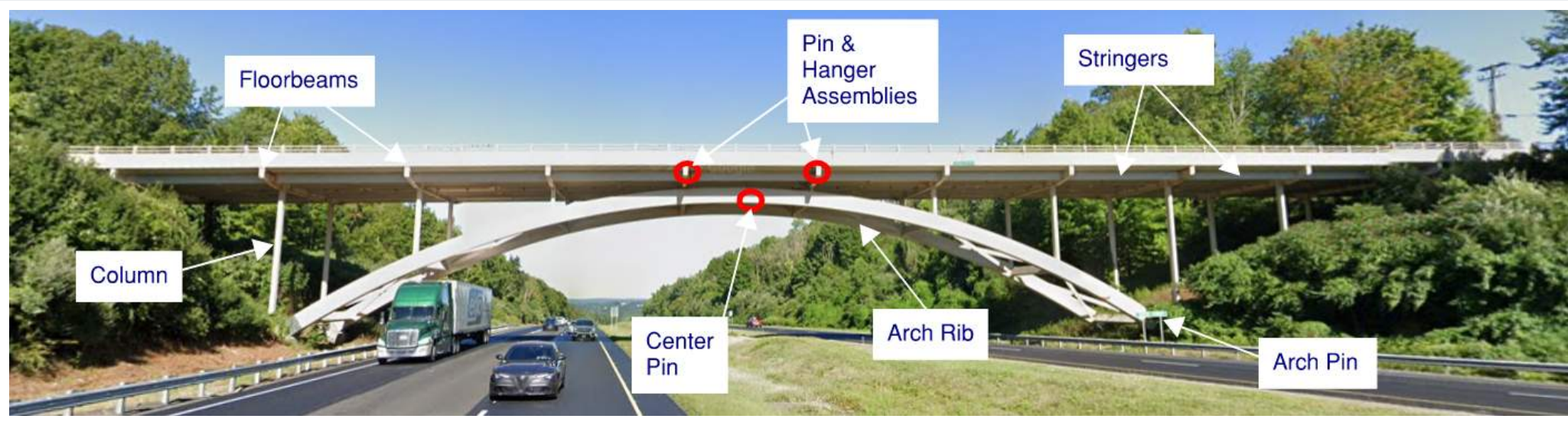

EXISTING CONDITIONS

- Pin & Hanger and Arch Pin Assemblies are considered fracture critical bridge components.
- Reason pin and hanger assemblies were implemented:
 - Reduce analysis, design and complexity of construction
 - Accommodate thermal movement (Pin & Hanger only) and rotation of the bridge superstructure.

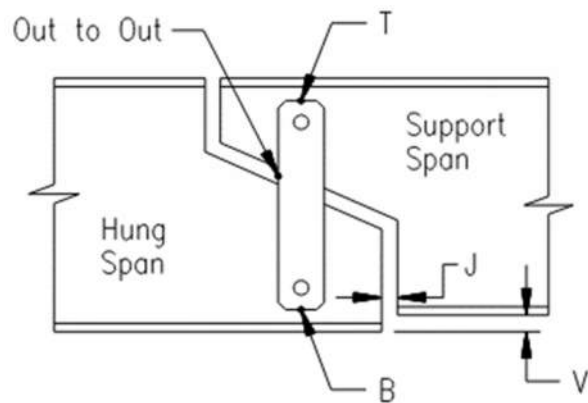

Pin & Hanger

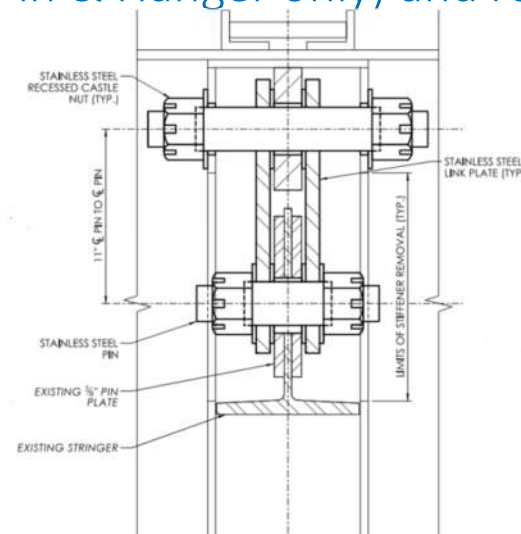

Section View



EXISTING CONDITIONS

Condition Rating – a judgement of a bridge component condition in comparison to its original as-built condition, used to provide an overall characterization of the general condition of the component being rated.

Bridge Condition Ratings

- 8 – Very Good
- 7 – Good
- 6 – Satisfactory
- 5 – Fair
- 4 – Poor



EXISTING CONDITIONS - DECK



Top of Deck



Underside of Deck



Safety Walk and Parapet



Joint at Pin & Hanger Assemblies



Strip Seal at Abutment

ITEM	CONDITION	RATING
Deck	Fair	5
• Overlay (None)	NA	-
• Deck – Structure	Fair	5
• Parapet*	Good	7
• Sidewalk	Good	7
• Deck Joints	Satisfactory	6
* Does not meet safety standards		

Rehabilitation of Bridge No. 01164 // State Project No. 0080-0312



EXISTING CONDITIONS - APPROACHES



South Approach



Transition – Approach
Guiderail to Bridge Endblock



North Approach

ITEM	CONDITION	RATING
Approach	Good	7
• Approach Slab	NA	-
• Relief Joints	NA	-
• Guide Rail*	Fair	5
• Approach Pavement	Good	7
• Embankment	Very Good	8
*Does not meet safety standards		

Rehabilitation of Bridge No. 01164 // State Project No. 0080-0312



EXISTING CONDITIONS - SUPERSTRUCTURE



Arch Column, Floor beam, and Stringers



Pin & Hanger Assembly and Stringer End



Floor beam Cantilever



Arch Rib

ITEM	CONDITION	RATING
Superstructure	Fair	5
• Bearing Devices	Fair	5
• Stringers	Fair	5
• Steel Arches (Girders)	Good	7
• Floor Beams	Fair	5
• Welds	Good	7
• Paint	Good	7

Rehabilitation of Bridge No. 01164 // State Project No. 0080-0312



EXISTING CONDITIONS - SUBSTRUCTURE



Arch Rib Abutment



Column Pedestal



Bearing condition at Abutment



ITEM	CONDITION	RATING
Substructure	Good	7
• Abutment (Stem/Backwall)	Good	7
• Wingwalls	Good	7
• Piers (Columns/Footings)	Good	7

Rehabilitation of Bridge No. 01164 // State Project No. 0080-0312



EXISTING CONDITIONS - UTILITIES



North Abutment – West Lines



North Abutment – East Lines



South Abutment – East Lines



South Abutment – West Lines
Rehabilitation of Bridge No. 01164 // State Project No. 0080-0312



PROPOSED CROSS SECTION

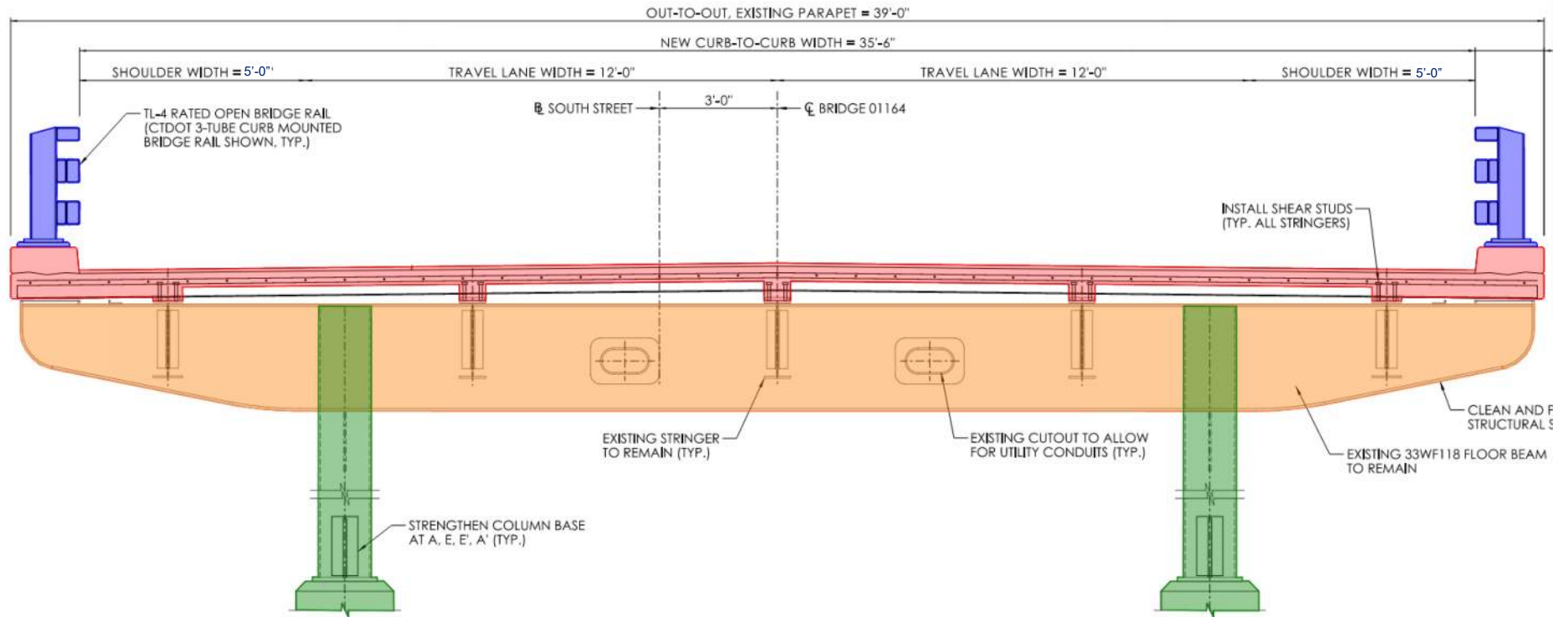

CROSS SECTION - TYPICAL FLOOR BEAM



SUMMARY OF WORK

- Replace deck with lightweight concrete
- Install new crash-tested bridge railing and end blocks
- Regrade approach roadways
- Replace wooden post barrier
- Replace affected driveway

- Replace pin & hanger assemblies
- Install redundant support systems below pin & hanger assemblies

- Steel strengthening
- Steel repair
- Bearing replacement

- Clean and Paint the full bridge



TRAFFIC MAINTENANCE

I-84

- Long-term Maintenance and Protection of Traffic (MPT) – temporary traffic barriers along shoulders
- Short-term single lane closures

South Street

- Full Bridge closure

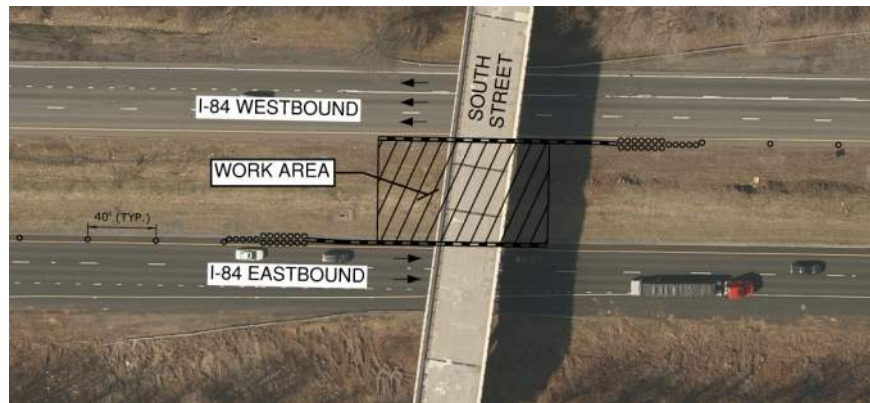

Stage 1



Stage 2

Rehabilitation of Bridge No. 01164 // State Project No. 0080-0312



TRAFFIC DETOUR PLAN

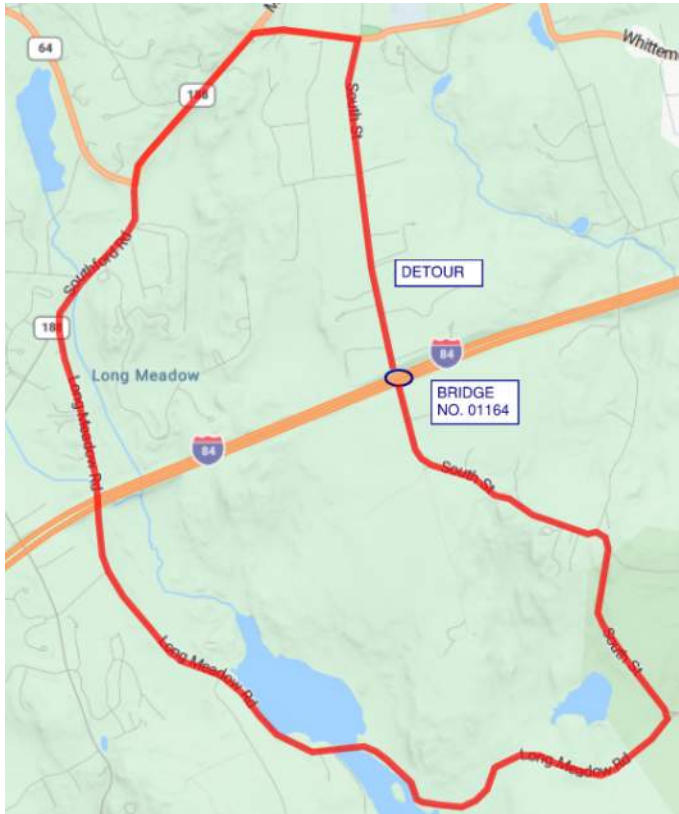

South Street Closure

- Full Bridge closure for construction duration (18 months)
 - Utilizes Long Meadow Road (6.2 miles)
- ADT
 - South Street 1700 VPD
 - Long Meadow Road 1600 VPD



PROJECT SCHEDULE AND COST

Schedule

- Preliminary Design – Current Phase
- Final Design Plans – 7/9/2025
- Design Completion Date – 8/20/2025
- Advertising for Construction – 9/17/2025
- Notice to Proceed – 1/26/2026
- Start of Construction – Spring 2026

Estimated Construction Cost

- Total Estimated Construction Cost = \$14.8 Million
- 80% Federal Funds, 20% State Funds
- No Town funds required

The Project Cost and Schedule are preliminary and are subject to change.



Question & Answer Session



by email: DOTProject0080-0132@ct.gov



by phone: **(860) 594-2020 (voicemail)**



by chat: **Zoom Q&A**



project webpage:

<https://portal.ct.gov/DOTMiddlebury80-132>

Moderator will answer questions in Zoom Q&A

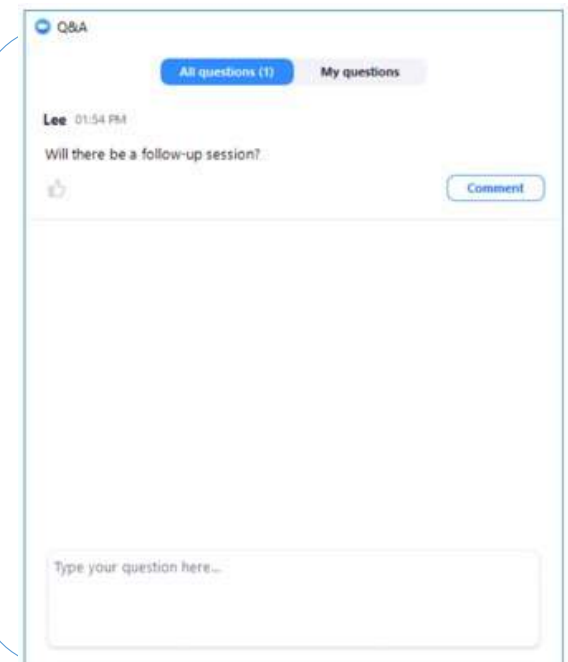

Note: Comment period is open through **March 19, 2024**

*Zoom Q&A is only available during live Q&A session

Rehabilitation of Bridge No. 01164 // State Project No. 0080-0312

